

# SUB WOOFER

# TPL 8

- 1 Surround TPR material
- 2 Gasket ABS injected
- 3 Cone PP injected
- 4 Spider CLOTH material
- 5 Dust Cap not present
- 6 Terminal 4,8x6,3 mm
- 7 Voice coil 32x23 mm. 4 layers Kapton former
- 8 Magnet system vented 8,0 mm. gap height
- 9 Magnet 115x56x18 mm.
- 10 Basket frame Steel material

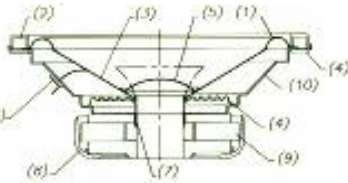

Frequency range	34 - 2000 Hz
Equivalent volume, Vas	32L
Compliance, Cms	0,465 mm/N
Mechanical resistance, Rms	0,80 Ns/m
Effektive diaphragm/cone area, Sd	214 cm <sup>2</sup>
Voice coil diameter	32 mm
Voice coil height	23 mm
Air gap height	8 mm
Linear excursion, Xmax	± 8 mm
Max mechanical excursion	±16 mm
Nominal impedance	4 ohm
Voice coil resistance	3,8 ohm
Voice coil inductance	1,7 mH
Free air resonance, Fs	34 Hz
Sensitivity, Spl (1W,1m)/(2.83V/1m)	84/87 dB
Force factor, Bxl	7,1 Tm
Moving mass, Md	42 g
Qms	12,60
Qes	0,68
Qts	0,64
Nominal power	120 W
Short term max power	240 W
Magnet weight	713 g
Total weight of driver	2150 g

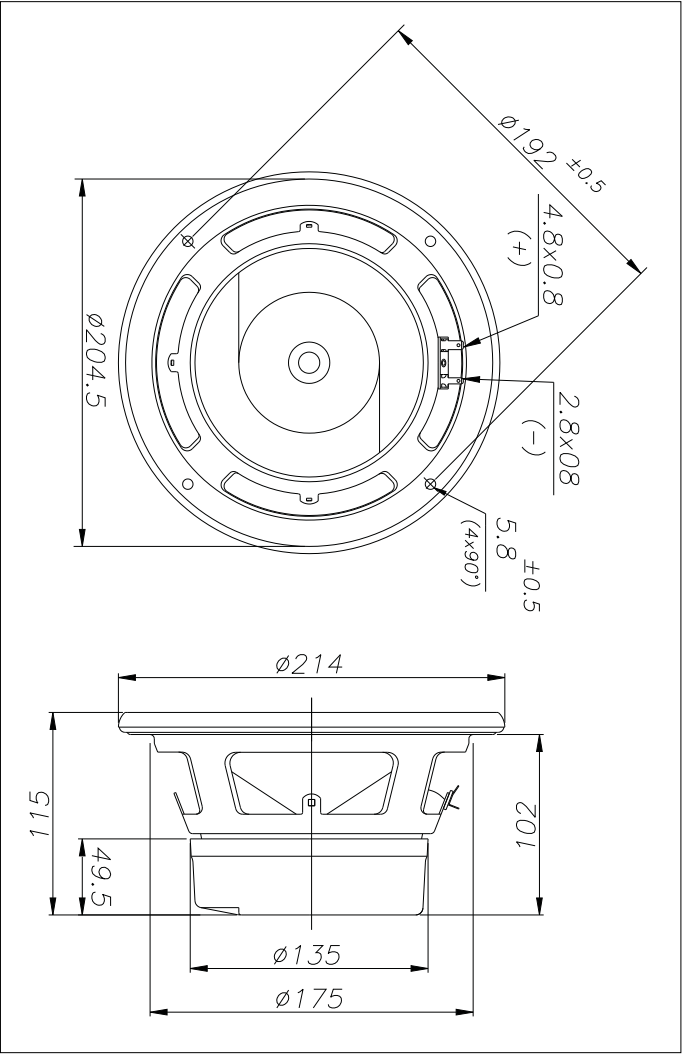

## SUB WOOFER SERIE TPL

### Sospensione pneumatica TPL 8

Vol [lt] volume netto	Qtc fattore di merito totale	F3 [Hz] frequenza a -3dB	A [mm]	B [mm]	C [mm]	D [mm]
10.8	0.50	44	270	320	260	210

Misure esterne al mobile di spessore 19 mm.  
Disporre materiale fonoassorbente alle pareti.

### Sospensione pneumatica TPL 10

Vol [lt] volume netto	Qtc fattore di merito totale	F3 [Hz] frequenza a -3dB	A [mm]	B [mm]	C [mm]	D [mm]
28.5	0.50	37	320	380	420	250

Misure esterne al mobile di spessore 19 mm.  
Disporre materiale fonoassorbente alle pareti.

### Sospensione pneumatica TPL 12

Vol [lt] volume netto	Qtc fattore di merito totale	F3 [Hz] frequenza a -3dB	A [mm]	B [mm]	C [mm]	D [mm]
46.3	0.50	33	340	460	470	350

Misure esterne al mobile di spessore 19 mm.  
Disporre materiale fonoassorbente alle pareti.

